



EGG BROCHURE

PACKAGING SOLUTIONS DESIGNED WITH NATURE IN MIND



HELLO & WELCOME

OUR SERVICE

At EGI we pride ourselves on the [service](#) we provide each and every customer. From product availability to packing advice and everything inbetween.

OUR PRODUCTS

We have created our sustainable **PUL^{it}** [range](#) specifically to protect fragile eggs during transit.

OUR PLANET & US

EGI's journey began with environment in mind. Understand how our business and products are [helping the planet](#).



Ezee Group International (better known as EGI), is a family-run business specialising in creating sustainable packaging solutions to reduce the huge impact of plastic on the environment. In the current market, developing your business to meet the ever increasing demands to be environmentally conscious is becoming a vital part of any business plan. Our products have been created with this in mind—combining sustainability with reliable performance.

With the growth of online food services, there is increasing demand for safe and secure egg transportation. Whether supplying meal kit subscriptions, diet and nutrition plans, farm shops, or local food delivery services, businesses need packaging they can trust to deliver eggs intact. To meet this need, we've designed and developed high-quality, sustainable protective packaging. Each product has been rigorously tested to ensure reliable protection throughout delivery networks.

Below is a detailed breakdown of our **PUL^{it}** products, manufacturing and eco credentials, as well as the key features that make our products unique and versatile within the online egg market.

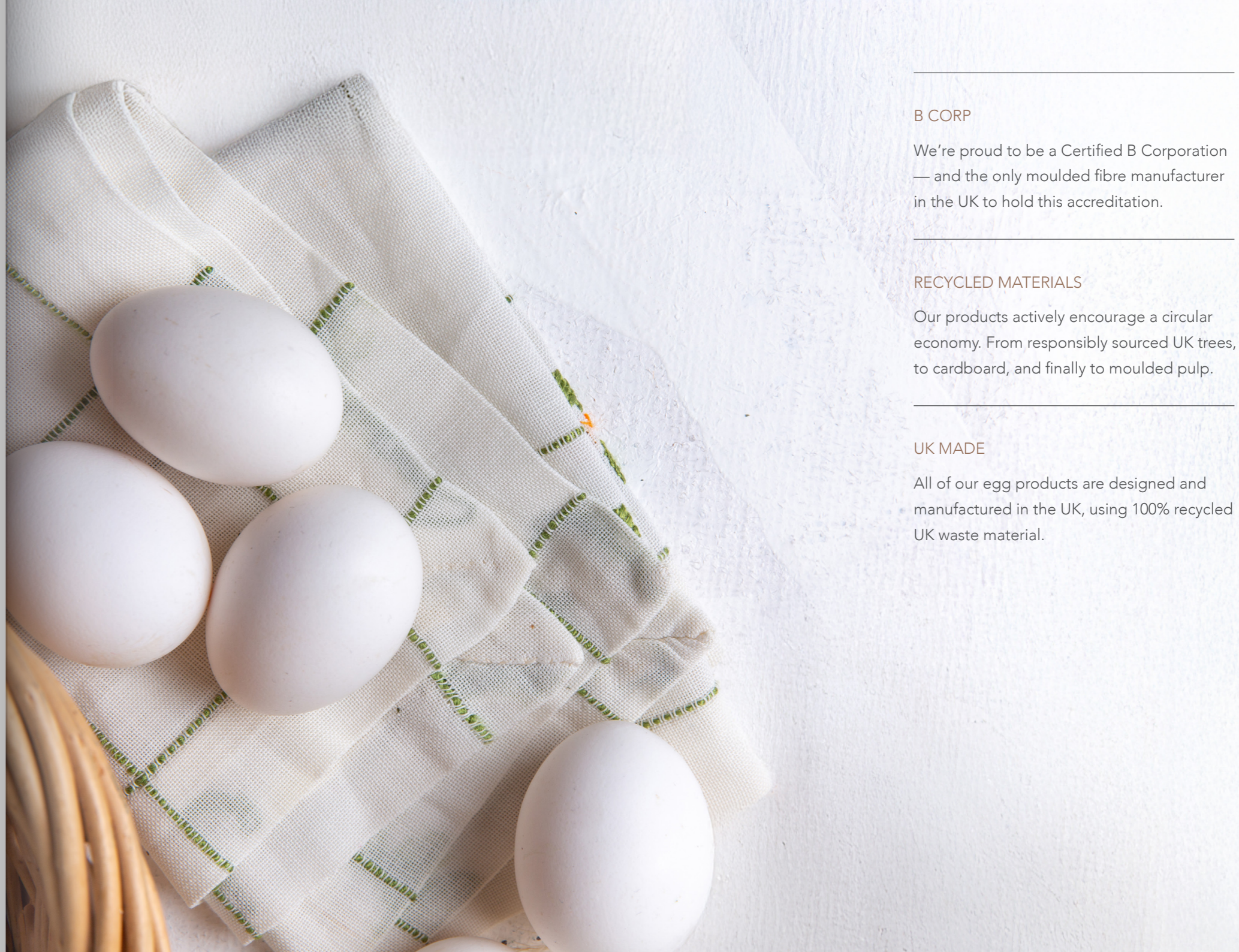

B CORP

We're proud to be a Certified B Corporation — and the only moulded fibre manufacturer in the UK to hold this accreditation.

RECYCLED MATERIALS

Our products actively encourage a circular economy. From responsibly sourced UK trees, to cardboard, and finally to moulded pulp.

UK MADE

All of our egg products are designed and manufactured in the UK, using 100% recycled UK waste material.



THE DESIGN

As specialists in the industry, EGI have over 16 years of research and development experience. Every product has been specifically designed and manufactured for the safe delivery of fragile items through the courier networks. We work with some of the best suppliers in the industry to create packaging that will withstand the products journey from beginning to end.

All of our products are designed using the best materials, design application and manufacturing processes.

Being both soft and strong is a combination very few have mastered.

TASMIN MOGAHED

Our product range has been designed and manufactured to accommodate a range of egg sizes, ranging from 30g to 73g (underweight to larger +)

We also offer a bespoke design service. Our in-house design team are adept at understanding our customers needs and designing custom made packaging to suit these requirements. We aim to understand your full operation which enables us to develop a product that not only enhances your offering but also saves you time, money and is sustainable to the planet.

THE DESIGN SERVICE

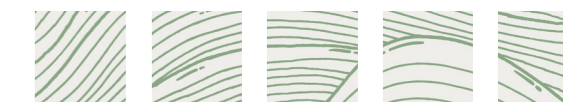

Our products have been designed with 4 key factors in mind, protection, cost savings, time savings and sustainability....

PROTECTION

Moulded fibre pulp boasts exceptional shock-absorbing properties for effective cushioning during transportation. Our products are carefully crafted to fully utilise these qualities, ensuring a precise fit for each product. Our precise designs enhance protection and minimise movement during transit, thereby reducing costs related to returns, replacements, and customer dissatisfaction.

SUSTAINABILITY

As a sustainable material, moulded fibre pulp contributes to reducing the environmental impact of packaging. The use of recycled materials helps conserve natural resources and reduces the carbon footprint associated with packaging production. All our products are bio-degradable, compostable and recyclable, offering a comprehensive and planet-conscious solution.

COST SAVINGS

Our products are designed to provide a precise fit, minimising wasted space and facilitating efficient packing and transportation. In addition to the tailored fit, our packaging is inherently lightweight. This dual focus on size and weight results in significant savings per shipment on delivery costs. This also enhances the efficiency of your supply chain, ultimately reducing overall costs.

TIME SAVING

We have created an easy use system, making our products quick to pack, saving you time and money. Being easy to pack; you could reduce your warehouse packaging time significantly. Forget wrapping, sticking, and folding—our packaging takes only 3–10 seconds! Place the egg, snap it shut, and you're done. With the 4-egg, just place, close, and slide on a sleeve. Quick, simple, and built to save you time.

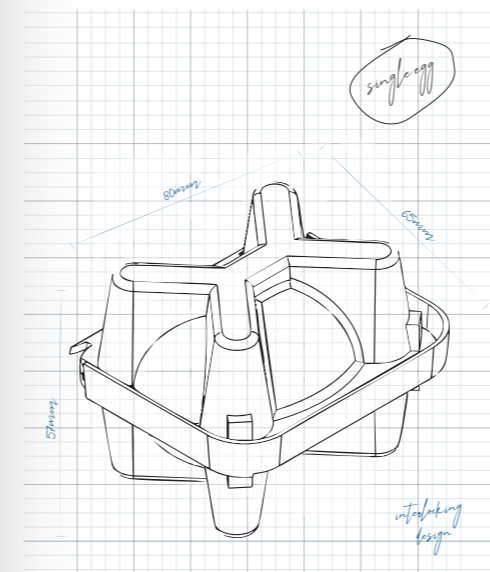

THE PULPIT RANGE

SUSTAINABLE

Made in the UK from 100% waste materials. All products are biodegradable, recyclable and compostable

AVAILABILITY

Reliable and consistent supply with orders dispatched within 1-day*

COURIER FRIENDLY

Our products are courier approved with no additional packaging required.

* Dependant on product and volumes.

Diagrams for illustrative purposes only. Not to scale.

PACK IT, PROTECT IT, POACH IT...

One size does not fit all when it comes to protective packaging. Each variation of product requires it's own adapted design to fully protect your product. This is why we consult with each customer to fully understand their products and ensure we recommend the right solution. Our **PULPIT** egg range includes variations suitable for shipping 1, 2, 3 & 4 eggs, ensuring your products have the best protection.

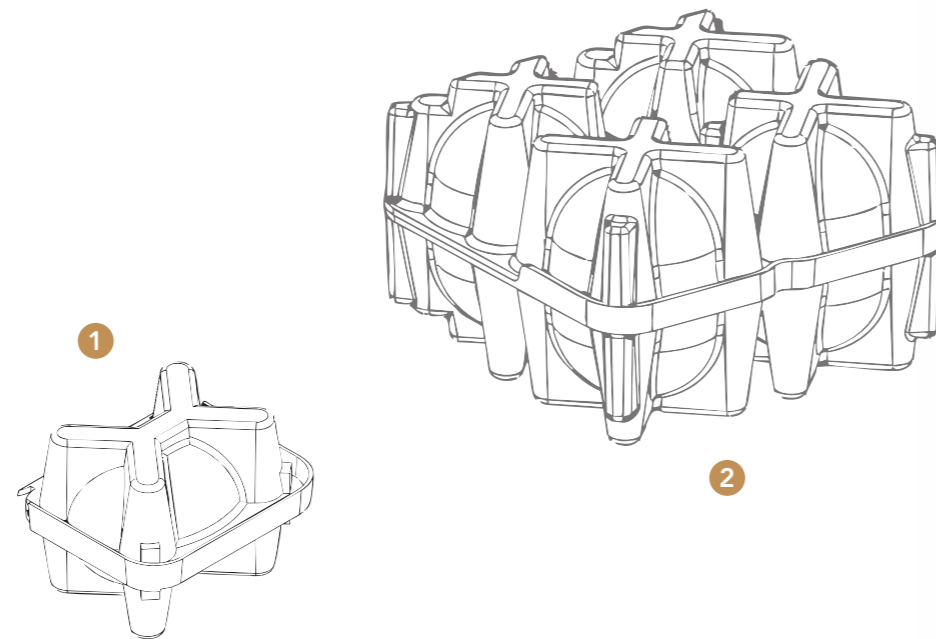

1 SINGLE EGG

Our egg packaging is designed to securely ship a variety of egg sizes through courier networks, accommodating weights from 30g up to 73g, from smaller underweight eggs to larger+ sizes. The single-egg pack offers a modular design for maximum flexibility. It can be used on its own to ship a single egg, or two moulds can be paired together to safely ship two eggs using the interlocking design. And if you need to send three eggs, simply use a combination of the two.

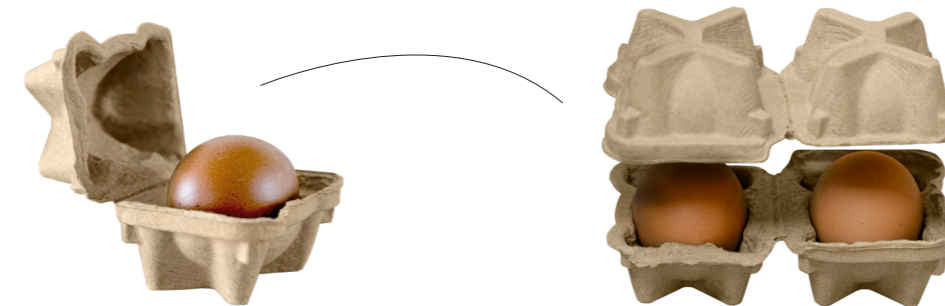

PRODUCT BREAKDOWN



2 4 EGG SOLUTION

Our 4 egg packaging is designed to securely ship a variety of egg sizes through courier networks, accommodating weights from 30g up to 58g, from smaller underweight eggs to medium-.



THE PULPIT RANGE

SINGLE EGG CONFIGURATION

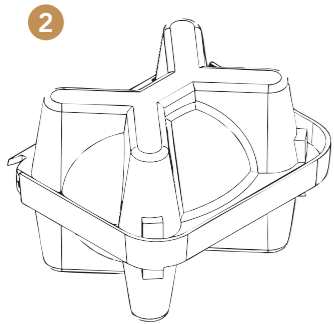
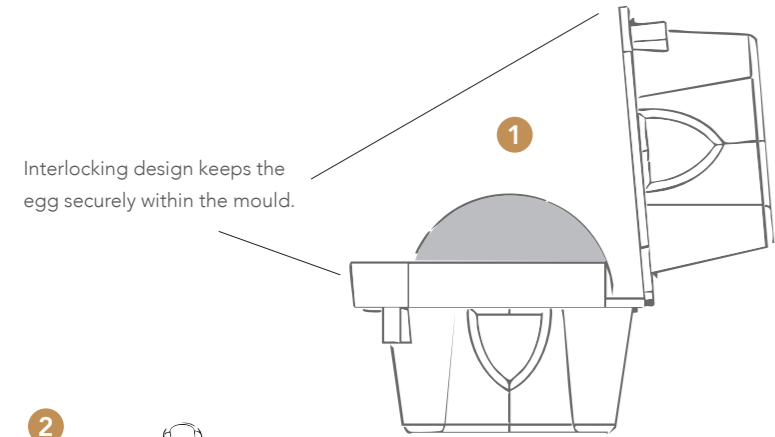

Interlocking design keeps the egg securely within the mould.

2-EGG CONFIGURATION

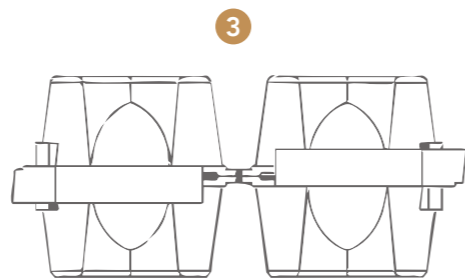
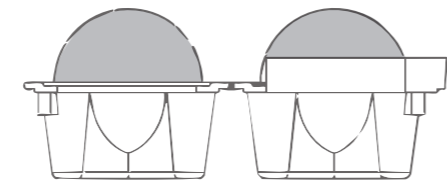
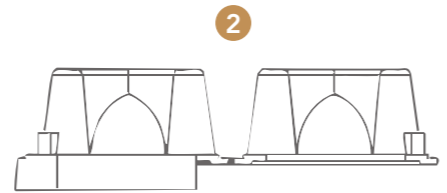
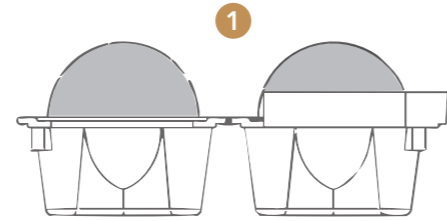

4-EGG CONFIGURATION

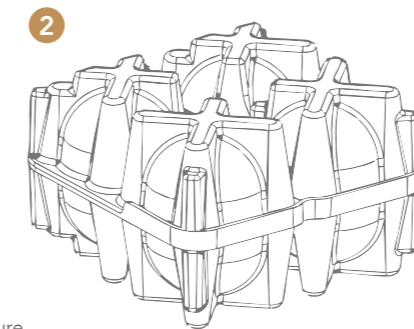
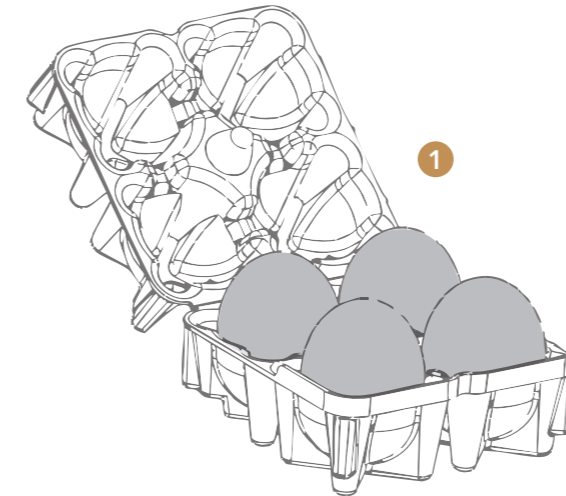

3 Add a cardboard sleeve to secure the moulds, while also providing a space to incorporate relevant information.

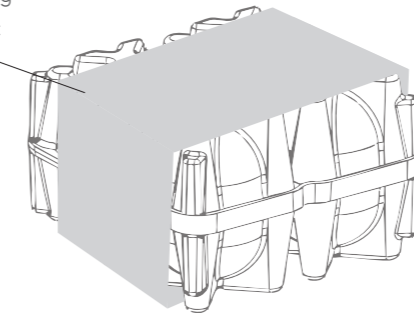

PRODUCT BREAKDOWN



PULPit

SINGLE EGG*	10'800 PIECES	HALF PALLET
SINGLE EGG* (DOUBLE CONFIGURATION)	5400 SETS	HALF PALLET
4-EGG* (2 PIECES PER UNIT)	640 UNITS	HALF PALLET

USEFUL INFO

* Mix and Match: You can mix and match these (*) products with any other half pallet to create a full height pallet. For example you can have a half pallet of 'Single Egg' and half a pallet of '4-Egg' stacked together to make a full height pallet. Saving on delivery costs.

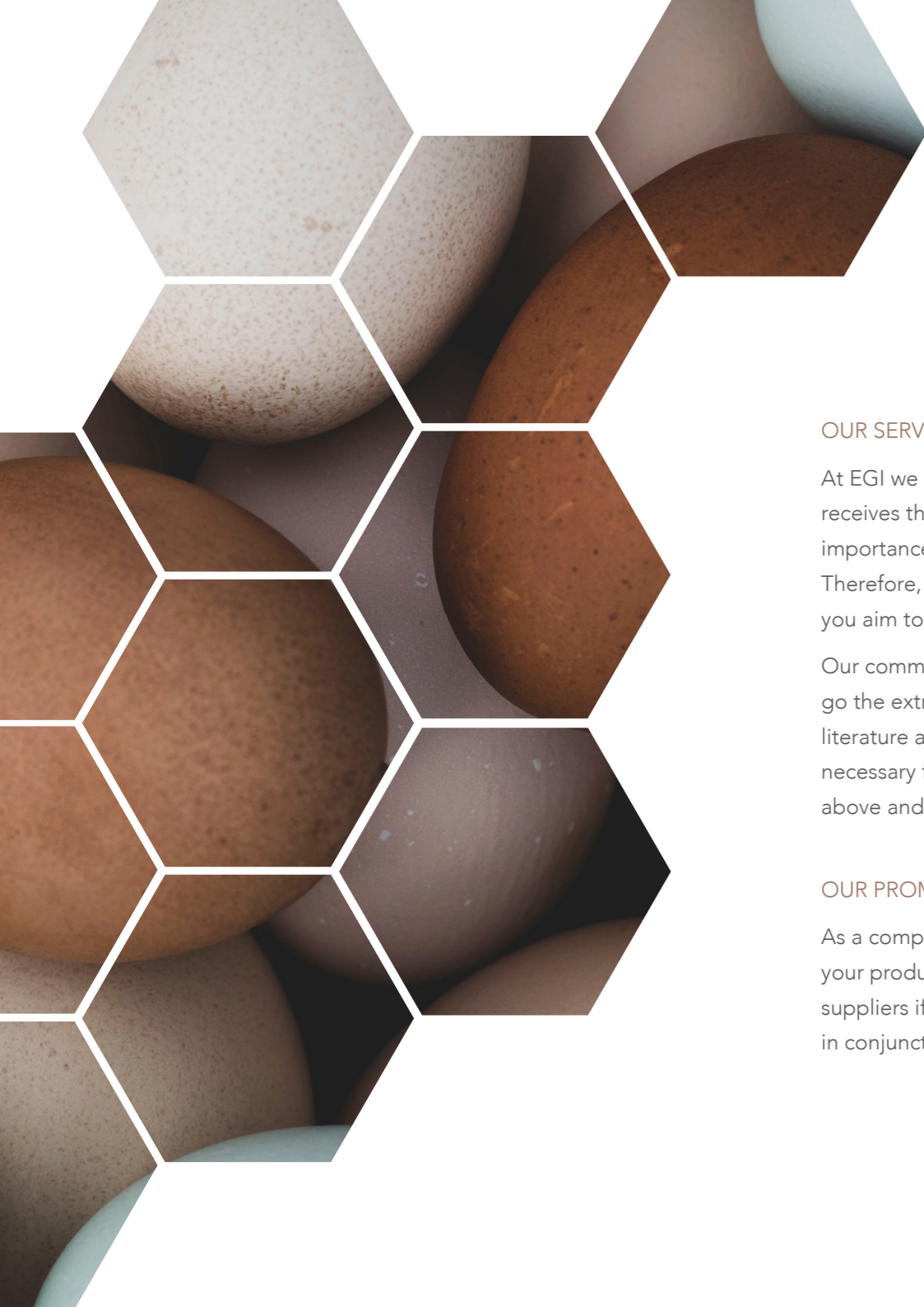

OUR SERVICE

At EGI we value each and every customer equally. Regardless of size, each customer receives the same level of dedicated support and service. We recognise the paramount importance of high-quality products and service in the E-commerce/B2B landscape. Therefore, EGI is devoted to delivering a service that aligns with the exceptional standards you aim to provide to your own customers.

Our commitment extends beyond prompt and reliable delivery and customer service; we go the extra mile by offering comprehensive training sessions and providing informative literature and guides. Our goal is to empower our customers with the knowledge and skills necessary for optimal product usage and secure packaging. We pride ourselves on going above and beyond to support you every step of the way.

OUR PROMISE

As a company we will only recommend our packaging if we feel it is the best solution for your product. EGI operates a multi-faceted approach and will engage other specialist suppliers if we believe their products are more suitable to your operations. Whether this be in conjunction with or independently of ours.

THE EGI SERVICE

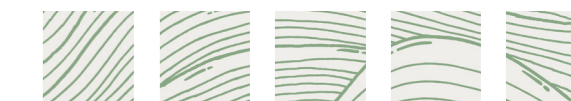

Some of the key services we offer include stock availability, samples, advice, delivery service and certifications & approvals....

CERTIFICATIONS & COURIER APPROVALS

Our products undergo extensive live courier trials to ensure the effectiveness of our products. We are accepted by a range of couriers and are a **DPD APPROVED** supplier.

At EGI, we prioritise the utmost reliability and durability in our offerings. Products are tested in-house to our EGI/DPD drop test standards. However, should you require additional certifications or testing, EGI is more than willing to collaborate with you to meet those requirements.

ADVICE & CUSTOMER SERVICE

The EGI team is readily available to assist customers at any stage, offering guidance on packaging solutions, box branding, and more. We are dedicated to providing prompt support, ensuring that all orders and queries receive a response within 24 hours.

DELIVERY SERVICE

We work with a select group of couriers to provide a fast and efficient delivery service. By obtaining live quotes from our couriers, we ensure that you receive the most competitive rates for each delivery, whether it's a box, half a pallet, or a full lorry load.

STOCK AVAILABILITY

At EGI we consistently maintain our stock levels to facilitate swift shipping. This ensures that all our customers can place orders with confidence and efficiently plan their ordering schedules.

FREE SAMPLES

EGI offer all customers free samples. This allows our customers to personally assess the quality of each product and conduct thorough testing before making a commitment.



* These certifications do not apply to all of our product range. Please liaise with our sales team to find out what testing and certifications apply to the products you are interested in.



EGI AND THE PLANET

JUBILEE PARTNER

Alongside the Queens Jubilee Trust, EGI have planted 500 trees and 600 hedges. As a business we try and create a closed loop with the resources we use.

GIVING BACK

At EGI, we are committed to giving back, and that's why we proudly support The Lewis Moody Foundation, Nicholls Spinal Injury Foundation, Naomi House, Jack's Place and MND Charities, as well as other local and national charities.

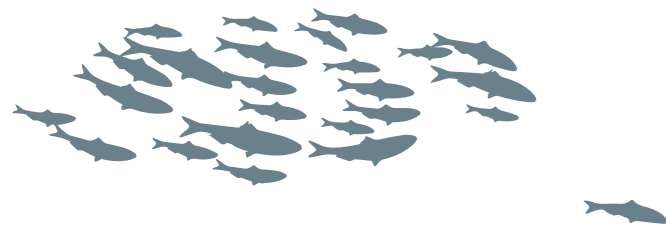

OUR ECO JOURNEY

Inspired by the profound impact of plastic pollution showcased in documentaries like Blue Planet, Managing Director - Natalie felt a responsibility to contribute to a greener, more sustainable future. In response to this environmental call-to-action, EGI was born, envisioned as an eco-friendly moulded fibre packaging alternative to plastic.

OUR AIM

At our core, our company's primary goal is to safeguard the '3 P's' – your Product, your Profits, and the Planet. We achieve this by developing strong products that eliminate plastic, polystyrene, and foam packaging from the equation, in favour of an eco-conscious alternative. Our products not only reduce plastic pollution but also prevent your items from becoming damaged waste, benefitting both your pocket and the planet.

OUR COMPANY ACTIONS

Sustainability is a shared responsibility, and at EGI, we are consistently taking steps to minimise our carbon footprint. Presently, all our products are manufactured and stored within a 30-mile radius, significantly lowering transportation-related carbon costs. Our warehouse operations are powered by electric vehicles, and our products are manufactured using only waste materials. EGI is committed to ongoing adaptations for a more sustainable business model, all while delivering products that contribute to your sustainability goals.



EGI understands that, although our products are crafted from waste cardboard, trees were cut down in the creation of this original material. With this awareness, as a company and as people, we are continually striving to enrich the natural environment.

REWILDING PROJECT

We have actively engaged in rewilding the local land by planting trees, hedgerows, and wildflowers. This project, in turn, creates habitats that provide food, homes, and safe shelters for a diverse range of animals.



CONTACT US

To discuss what we can offer your business please contact us.

01858 575 454

sales@egipulp.com

EGIPULP.COM

Certified



Corporation